

TB20e
electric power

2-TONNE



COMPACT ELECTRIC EXCAVATOR

100% BATTERY POWERED



TAKEUCHI
From World First to World Leader

TB20e
electric power

NEW ELECTRIC compact excavator

The TB20e is the latest innovation in the Takeuchi excavator line-up. A fully electric machine, and the first Takeuchi excavator to feature electro-hydraulic controls.

Built with the same all steel construction, heavy duty boom and retractable under carriage, matching the performance of its diesel TB216 equivalent.

The TB20e is ideal for applications in noise sensitive areas such as schools or hospitals, operating at 80dB and 15% quieter than a diesel excavator. This environmentally friendly option offers a more sustainable choice.



980mm \longleftrightarrow 1300mm
Expanding undercarriage





100% ELECTRIC

ZERO EMISSIONS

TB20e

electric power



- 24.7kWh Lithium-Ion battery
- Retractable undercarriage
- Full charge runs 8 hours - 65% load
- Matches the performance of a diesel equivalent (TB216)

THREE CHARGING OPTIONS

- On-board – domestic
- Tethered – when operating
- Optional Off-board – 3 phase fast

8 HOURS OPERATING

The TB20e is 100% battery powered with zero exhaust emissions. With a full charge the 24.7kWh maintenance free lithium-ion battery provides up to 8 hours of operating time at 65% load.

CHARGING OPTIONS

The TB20e features as standard an on-board charger, 95V to 265V single-phase

- On-board charger - charge static
- On-board charger - charge whilst operating

Optional off-board Fast Charger, 408V to 552V

- 3-phase Fast Charge

The optional off-board Fast Charger is available for fast 3-phase charging. Easy to transport with a simple hook-on to the dozer blade. (See back page for charging times).



**FULL
3-YEAR
3,000 HOUR
WARRANTY**

Takeuchi machines come with a full 3 year/3000 hour warranty as standard, terms and conditions apply.

Before fitment of a hydraulic attachment, machine auxiliary pressure and flow should be accurately measured. For all lifting specifications please refer to the lift charts on the Takeuchi website or operator manual.

In accordance with our established policy of constant improvement, we reserve the right to amend these specifications at any time without notice. Photographs shown may feature non-standard equipment.



PRODUCT FEATURES & SPECIFICATIONS

OPERATOR STATION

- 4.3" high definition, multifunction colour display
- ISO/SAE pattern change valve via monitor
- ROPS/TOPS/OPG (Level 1)
- Suspension seat
- Retractable seat belt
- Foldable travel pedals
- Boom swing pedal, with foldable footrest
- Emergency stop switch
- Safe start system (left console)

ZERO EMISSION ELECTRIC POWER

- 24.7 kWh lithium-Ion battery
- 100% battery powered with zero emissions
- Reduced sound and vibration levels
- ECO mode

CHARGING

- On-board charger - charge static
 - On-board charger - charge whilst operating
- Optional Fast Charger
- Off-board Fast charger - reducing charge time to 2-4 hours

ELECTRICAL

- Weather resistant rocker switches
- LED light package; boom, canopy, rear
- Travel alarm
- 12V battery disconnect switch
- Hour meter/trip meter
- 12V power outlet
- TFM (Takeuchi Fleet Management)

ELECTRO - HYDRAULIC

- 2 electric motors
- Load sensing system for operation
- Electro-hydraulic joysticks
- First auxiliary circuit with proportional control
- Detent for first auxiliary circuit
- Autotank
- 1st, 2nd and 3rd as standard. First auxiliary plumbed to mid-arm
- Adjustable hydraulic flow on first auxiliary
- Cushioned boom and swing cylinders
- Top mount boom cylinder
- Boom and arm holding check valves
- Lift alarm
- Steel hydraulic tank with fluid level sight gauge

UNDERCARRIAGE AND FRAME

- Triple flange track rollers
- Hydraulically retractable undercarriage
- Adjustable width dozer blade
- Two-speed travel with auto step down
- Wraparound protective counterweight
- Rubber tracks 230mm



TFM - TAKEUCHI FLEET MANAGEMENT

The TB20e comes with TFM as standard. TFM is a remote TELEMATICS system, using real time data to better manage your fleet and lower overall operating costs. Free of charge in warranty period.



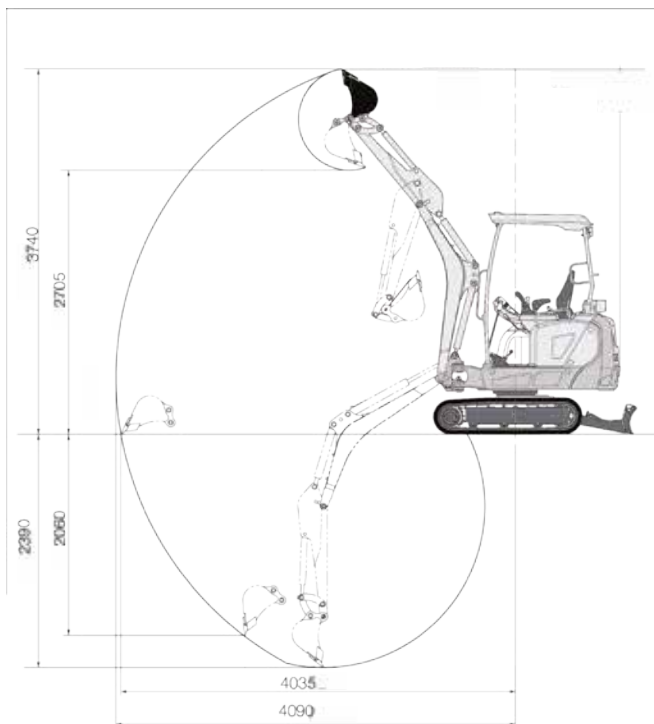
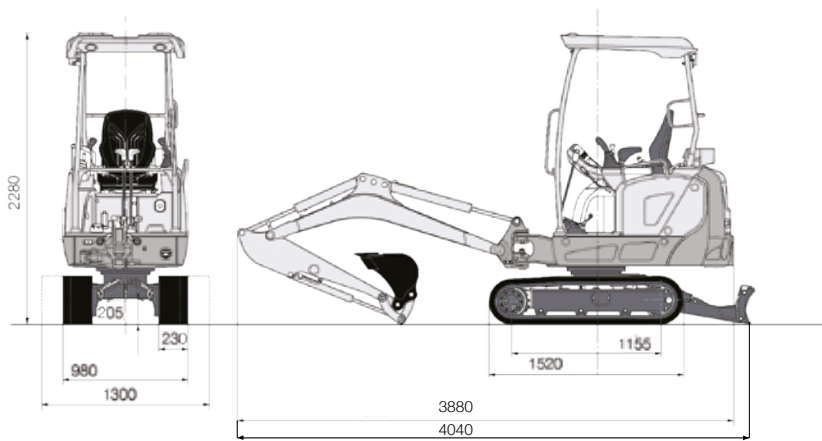

All dimensions unless otherwise stated are in millimetres.

TB20e Standard UK Specification Canopy - Long Arm / Rubber Tracks

Lithium Ion Battery	
Battery Capacity (kWh)	24.7
Battery Voltage (V)	73
WORKING TIME	
Continuous Working Time @ 65% Load	Up to 8 Hours
BATTERY CHARGE HOURS	
Off-Board Charger @ 340 - 460V	Approx. 2 hours
On-Board Charger @ 95 - 265V	Approx. 6 hours
BATTERY CHARGE HOURS	
Off-Board Charger @ 340 - 460V	Approx. 4 hours
On-Board Charger @ 95 - 265V	Approx. 10 hours
Lead-Acid Battery	
Battery Capacity (IEC 60095-1)	12V-45A . h
Dimensions & Weight	
Operating Weight (kg)	2011
Fast Charger Weight (kg)	71
Width (mm)	980 - 1300
Length (mm) (overall)	4040
Length (mm) (transport)	3880
Height (mm)	2280
Ground Clearance (mm)	205
Front Swing Radius (mm)	1480
Tail Swing Radius (mm)	1075
Operating Information	
Max. Dig Depth (mm)	2390
Max. Dump Height (mm)	2705
Max. Ground Reach (mm)	4035
Max. Vertical Dig Depth (mm)	2060
Maximum Bucket Breakout Force (kN)	13.7
Maximum Arm Digging Force (kN)	8.1
Travel Speed 1st (km/h)	2.1
2nd (km/h)	4.0
Slew Speed (rpm)	7.6
Boom Swing Angle (Left/Right)	78°/49°
Gradeability	15°
Ground Pressure (kPa)	32.1
Traction Force (kN)	20.7
Hydraulic System	
System Pressure (bar)	206
Pump Type	2 x Gear
1st Auxiliary Maximum Flow (l/min) / Pressure (bar)	34/180
2nd Auxiliary Maximum Flow (l/min) / Pressure (bar)	11/210
3rd Auxiliary	
Low Pressure - for engage (bar)	34
High Pressure - for release (bar)	215
Hydraulic Breaker	
TKB72 (working weight kg)	105
TKB72-S (working weight kg)	135
Safety and Health	
Noise / Sound Power Level (LwA)	80dB
Vibration Hand Arm / Body (m/sec ²)	≤2.5 / ≤0.

**FULL
3-YEAR
3,000 HOUR
WARRANTY**

Takeuchi machines come with a full 3 year/3000 hour warranty as standard, terms and conditions apply.

Before fitment of a hydraulic attachment, machine auxiliary pressure and flow should be accurately measured. For all lifting specifications please refer to the lift charts on the Takeuchi website or operator manual.

In accordance with our established policy of constant improvement, we reserve the right to amend these specifications at any time without notice. Photographs shown may feature non-standard equipment.

For more information locally contact:



SCAN ME

To find your local dealer

Takeuchi Mfg (UK) Ltd, Unit E2B Kingsway Business Park, John Boyd Dunlop Drive, Rochdale, Lancashire OL16 4NG
info@takeuchi-mfg.co.uk www.takeuchi-mfg.co.uk

@TakeuchiUK

TAKEUCHI
From World First to World Leader