

TB250-2
5-TONNE



**POWERFUL
EXCAVATOR**

EXCAVATING EXCELLENCE

TAKEUCHI
From World First to World Leader

TAKEUCHI
From World First to World Leader

5 tonne compact excavator - powerful performance

The TB250-2 compact excavator brings operators the most comfortable operation and powerful digging performance.

Weighing in at 5120kg the TB250-2 excavator offers massive operating capacity in a compact sized excavator even in the toughest, tightest working conditions.

Performing with massive bucket breakout force the TB250-2 works comfortably well above expectations in the 5 tonne weight class.

STAGE V ✓
READY

POWERFUL BREAKOUT FORCE & INCREASED REACH

Powered by a Yanmar 4TNV88C with DPF, to meet Stage V emission regulations.

Fuel efficient with automatic idle, dial throttle control with economy work-mode and electronic engine monitoring.

The TB250-2 features 37.2 kN bucket breakout force and 22.9 kN digging arm force – high power for a 5 tonne excavator.

With a massive ground reach of 5985mm and dig depth of 3780mm the new TB250-2 offers lots more on site.



ENHANCED FEATURES

Two way auxiliary hydraulics plumbed to the boom arm allows alternative tools to be used on site.

NEW - the TB250-2 comes with factory-fitted hydraulic hitch pipework as standard.

Operating attachments is easy and controlled using the variable slider control on the left hand lever.

Auxiliary flows adjustable from the cab control panel

Electric throttle control makes it easy to set the throttle to the desired position for operation.

On site, the 5 tonne compact excavator is best known for reliable performance and regarded as a favourite by many operators for both comfort and control. Takeuchi achieve this with highly engineered reliable and touch sensitive controls.

The light touch gives the operator far more accurate control when digging in tough ground conditions with excellent hydraulic power when required. The higher than average bucket breakout force gets a greater digging performance

Tip up and operating balance are offset by centrally positioned counterweights. The TB250-2 offers excellent dig depth of 3780 mm. The roomy isolated cab minimises the impact felt by the operator.

If you're familiar with Takeuchi compact excavators the TB250-2 offers proven reliability and performance for plant hire, ground works, civils, earthmoving, utilities and much more.

With a reputation for reliability, Japanese build quality makes all the difference.



OPERATOR COMFORT

The stylish cab comes with a fully adjustable seat and arm rest.

Radio/MP3 socket, drinks holder and additional foot and storage room.

The TB250-2 is fitted with both foot pedal and hand travel lever controls. Operators familiar with larger excavators often prefer traditional foot pedals to hand lever options.

Air conditioning as standard on the TB250-2.





BUILT FOR SITE

The TB250-2 is built for site, with a strong cast steel wraparound and 100% steel panels.

Well positioned hydraulic hoses minimize potential damage and are well protected. Tough components and heavy duty design adds to durability.



REDUCED TAIL SWING

The compact TB250-2 features a shorter than average tail swing compared to conventional 6 tonne excavators. Just 1360mm tail swing radius combined with maximum 430mm overhang at 90° to track, rounded corners and enhanced all round visibility, helps minimise potential machine damage in restricted areas.



RELIABLE TRACK DESIGN

Triple flange rollers and maintenance free bearings add to tracking performance, built for rough terrain to provide many hours of continuous service.

PERFORMANCE

- Two speed tracking and simultaneous cab swing and dig functions all add up to faster working speeds.
- Short pitch rubber tracks add to performance with far less potential for ground damage.
- Emergency shut-off valve, if the boom or dipper cylinder hose for lifting is ruptured, the emergency shut-off valve is activated to prevent the boom or dipper from falling rapidly.
- Overload warning device - if a weight greater than the lifting capacity is applied or lifted, the overload warning device is activated and the horn sounds.

OPERATION

A comfortable cab incorporates useful operating features;

- Pilot operated joystick controls and foot pedals makes for easy uncomplicated drive and operations.
- Adjustable seat and arm rests.
- Two way auxiliary hydraulics plumbed to the boom arm allows alternative tools to be used on site.
- Well positioned controls make for comfortable all day operation.

SAFETY & SERVICE

- Electronic engine monitoring.
- Automatic fuel bleed system.
- Remote slew lubrication system.
- Vandalism protected lockable fuel tank and engine compartment.
- Hydraulic oil cooler.
- Engine oil Safe Drain system.
- All Takeuchi machines come with a 2 year/2000 hrs warranty as standard (*exceptions apply).

OPTIONS

- Quick Hitch
- Steel tracks.
- Breakers - TKB302-S, TKB 402-S

PROTECT YOUR INVESTMENT

The TB250-2 comes with **TSS Takeuchi Security System** as standard.

- Only programmed keys for start-up
- Un-programmed keys alert the operator via the VDU and alarm
- Standard - 1 red master key and 3 black users keys
- Can programme up to 13 black user keys





MAXIMUM ALL DAY COMFORT WITH A HIGH VISIBILITY CAB

The TB250-2 has the operator in mind, the large comfortable isolated cab minimises the impact felt. With a sliding 10-way adjustable suspended seat, headrest and ergonomically positioned hand and foot controls, plenty of foot room, high capacity automatic climate control, heater and defrost options.



The TB250-2 offers operators excellent all round visibility; LED work lights as standard, a retractable front window with a removable lower window section, a large skylight with sun shade and a rainguard for a dryer working environment.

A well positioned colour visual display unit illuminates active operating switch functions; lift overload, power altitude, auto idle and auxiliary detent. Operators can easily select auxiliary preset modes to match all types of attachments.



TB250-2 SERVICEABILITY

The new styled engine hood and side cover provide unparalleled access to engine and hydraulic components simplifying all aspects of machine maintenance - all accessible at ground level.

- Well positioned hydraulic and fuel tank gauges and hydraulic control valve
- Easy access electric refuelling pump as standard with auto shut off, stowed in own compartment
- The rear bonnet provides access to the engine service points
- Automatic fuel bleed system

Side-by-side radiator and hydraulic oil cooler ensures fresh cool air reaches each cooler, improving efficiency and component life. The A/C condenser is mounted on a hinged frame - decreasing inspection and cleaning time.



TFM - TAKEUCHI FLEET MANAGEMENT

Takeuchi Fleet Management (TFM) is designed to help you better manage your fleet and lower your overall operating costs. With TFM monitoring you can check the health of your equipment and prevent costly repairs by keeping track of alerts, hours and much more.

MINIMISE DOWNTIME - proactive monitoring increases machine health, reduces risk and keeps machines running.

REMOTE DIAGNOSTICS - reduce service trips by remotely capturing run hours and equipment data.

UTILISATION TRACKING - make decisions based on actual machine use.

PROACTIVE MAINTENANCE - schedule maintenance based on machine hours; saving time, parts and money.



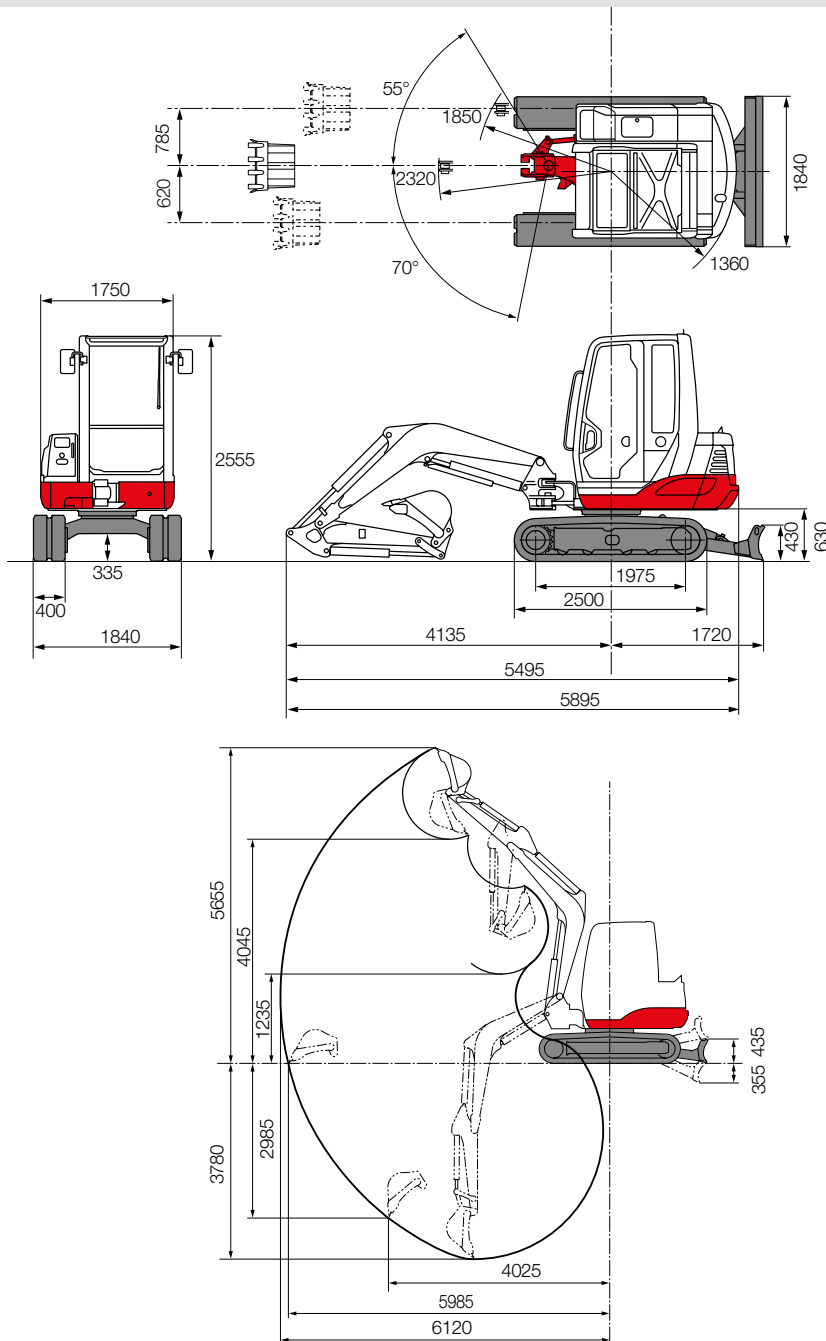

All dimensions unless otherwise stated are in millimetres.

For more information locally
call us direct, or contact:

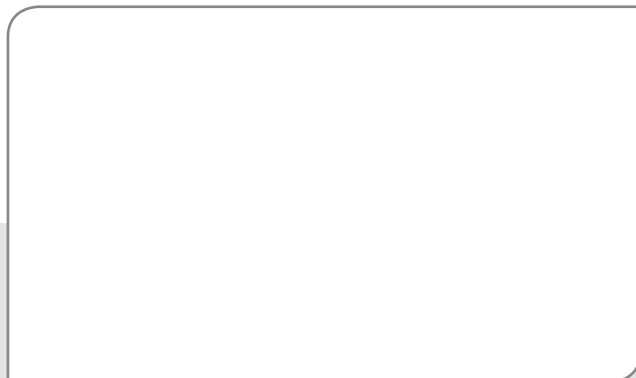

Takeuchi Mfg (UK) Ltd, Unit E2B Kingsway Business Park,
John Boyd Dunlop Drive, Rochdale, Lancashire OL16 4NG
Tel: 01706 657 722 Fax: 01706 657 744

Southern Depot at 20 Colthrop Business Park
Colthrop Lane, Thatcham, Newbury, Berks RG19 4NB
Tel: 01635 877 196 Fax: 01635 877 195

www.takeuchi-mfg.co.uk Email: sales@takeuchi-mfg.co.uk

**FULL
3-YEAR
3,000 HOUR
WARRANTY**

Takeuchi machines come with a full 3 year/3000 hour warranty as standard, terms and conditions apply.

Before fitment of a hydraulic attachment, machine auxiliary pressure and flow should be accurately measured. For all lifting specifications please refer to the lift charts on the Takeuchi website or operator manual.

In accordance with our established policy of constant improvement, we reserve the right to amend these specifications at any time without notice. Photographs shown may feature non-standard equipment.

TB250-2 Standard UK Specification - Long Arm/Rubber Tracks

Engine	
Make	YANMAR
Model	4TNV88C-PTB DPF
Rated Output (kW)/rpm	28/2400
Maximum Torque (Nm)	131.8-143.4
Cylinders	4
Displacement (cc)	2189
Electrical System	12 volt 90 amp

Dimensions & Weight	
Operating Weight (kg)	5120
Overall Length (mm) for transport	5495
Width (mm)	1840
Height (mm)	2555
Ground Clearance (mm)	335
Min. Front Swing Radius (mm)	1850
Slew Radius (mm)	1360
Dozer Blade (W x H) (mm)	1840 x 430

Operating Information	
Max Digging Depth (mm)	3780
Max Dump Height (mm)	4045
Max Reach at Ground Level (mm)	5985
Max Vertical Digging Depth (mm)	2985
Max Bucket Breakout Force (kN)	37.2
Max Arm Breakout Force (kN)	22.9

Hydraulic System	
Set Pressure (bar)	210
Pump Type	Rexroth Variable
1st Aux Max Flow l/min	91
Pressure bar	206
2nd Aux Max Flow l/min	38
Pressure bar	206

Swing System	
Boom Swing Angle (L/R)	70°/55°
Slew Speed (rpm)	9.8
Slew Motor	Piston
Slew Brake	Disc

Undercarriage	
Traction Motor	Axial Piston
Traction Drive	Planetary
Traction Brake	Disc
Track Width (mm)	400
Ground Contact Length (mm)	1975
Ground Pressure (kPa)	30
Travel Speed (km/h)	2.8 / 5.2
Maximum Gradeability	30°

Capacities	
Hydraulic System (l)	95
Fuel Tank (l)	70
Engine Lubrication (l)	7.4
Cooling System (l)	7.0

12/2024

TAKEUCHI
From World First to World Leader