

TB335R
3.8-TONNE



**SHORT TAIL
SWING EXCAVATOR**

3 SERIES

Takeuchi[®]
From World First to World Leader



NEW 3-SERIES TB335R short tail swing excavator

The TB335R is from the New 3-SERIES of Takeuchi excavators, packed full of value-added features offered as standard for maximum safety and productivity.

The short tail 3.8-tonne TB335R offers low emission and low noise with a Stage V (<19kW) engine. It comes with good bucket breakout force (27.1kN), in a compact size excavator and provides plenty of versatility on-site.

The TB335R combines all the proven characteristics of Takeuchi excavators: smooth hydraulics, power performance, proven durability, high resale value, with maximum operator comfort and serviceability.



MAXIMUM ALL DAY COMFORT

The stylish TB335R features a larger than average cab that provides easy roomy access and comes with air-con climate control as standard.

Operator comfort is maximized with a large adjustable high-back suspension seat, complete with head-rest.

The TB335R features an automotive styled Jog-Dial, for easier ergonomic control. The 7" colour touchscreen VDU illuminates all active operating switch functions

Extra cab features include a large skylight with sun-shade and a rain guard for open window operating. Electrics include DAB radio, Bluetooth, USB and microphone sockets.



COMPATIBLE BREAKER

The TB335R is compatible with a Takeuchi TKB102-S sound suppressed hydraulic breaker.

Designed to meet the requirement for quieter operating environments.





SHORT TAIL SWING

The TB335R offers a longer than average track frame for added stability and the unique short tail design provides excellent accessibility where space is limited.

The TB335R with just 950mm slew radius and a compact rear side, will work close to walls. The 75mm overhang at 90° to the track and rounded corners helps to minimise potential machine damage in restricted areas.

With a low centre of gravity and optimised counterweight the TB335R offers an extremely stable platform.



STANDARD FEATURES

(see website for the complete features list)

OPERATOR STATION

- All steel Cab (ROPS/ TOPS/ OPG)
- Large 7" touchscreen interactive Multi-Information colour display
- Adjustable seat and armrest with retracting seat belt.
- Radio - stereo speakers DAB/ Bluetooth/ USB and microphone sockets
- AC/ climate control/ heater/ de-mister
- Gas lift-assist window slides into recess
- Bolt-on handrails
- Steel folding fully supported travel pedals

ELECTRICAL

- Multi-switch control panel and jog dial
- Internal power sockets - 12V / USB
- Switched roof beacon socket - 12V
- Travel alarm / horn
- All around LED workzone lights - Front / Rear / Internal

ENGINE

- Stage V <19kW engine - low emission
- Dual fuel filtration with water trap
- Engine safe start system
- Electrical refuelling pump
- Service interval - 250 hours
- Working modes: Standard/ Eco



HYDRAULICS

- Cushioned boom, arm and swing cylinders
- Boom and arm holding check valves
- Clustered hydraulic test points
- Multi-attachment presets - password secure
- Aux with independent isolation valves
- Aux with auto tank
- Proportional auxiliary controls with detent
- Aux ports: 1st + 3rd (pre-piped for hydraulic hitch) 2nd + 4th optional

UNDERCARRIAGE AND FRAME

- Longer than average track frame
- Triple flanged track rollers & sealed bearings
- Dozer with switch activated blade float
- Dozer cylinder protection guard
- Secure-sure tie down anchor points



ENHANCED FEATURES

Visibility is enhanced with all around LED workzone lighting for maximum safety on-site. Enhanced blind side visibility via the larger and lower offside window.

Boom and arm holding valves are factory fitted for added safety in the event of a hose burst failure. An audible warning lift alarm is standard for craning.

Auxiliary hydraulic flows can be adjusted from the comfort of the operator's seat, with optional password secure presets.

The TB335R comes factory fitted with steel hydraulic pipework. Auxiliary Service Ports - 1st pre-piped for breaker and dual flow as standard. 3rd pre-piped for hitch with safe hand/foot activation switches.

MAXIMUM FUEL EFFICIENCY

Fuel Saving Features:

- Engine auto stop
- Automatic idle
- Economy work-mode
- Electronic engine monitoring
- Electric dial throttle control
- Two-speed tracking with auto step down



STAGE V COMPLIANT



SWITCH ACTIVATED BLADE FLOAT

To maximise ground finishing on-site the switch activated blade float is fitted as standard.

A heavy-duty dozer blade with a blade cylinder protection guard.

Exposed ground level hydraulic hoses are spiral steel wrapped for added protection.



TB335R SHORT TAIL SWING EXCAVATOR



MAXIMUM SERVICEABILITY

The TB335R features a full-width swing-out engine hood and a gas-lift side access panel to provide maximum 270° service accessibility. The hydraulics are easily accessed via a hinged low-line service door and easy-out floor panels.

REAR-ACCESS

The lockable swing-out all-steel hood provides unrestricted engine service access.

- Clustered service points give quick easy access for less service downtime
- Access to dipstick, dual air cleaners, cooling system, alternator and fan belt. Along with easy access fuel filtration, hydraulic pump and pilot filter

OFF-SIDE SERVICE PANEL

A lockable gas-lift all-steel hood provides unlimited service access.

- The fuel tank complete with an electric refuelling pump provides fast fill-up and has a cradle for safe storage. With auto-shut off and suction filter providing added safety when refuelling.
- Easy accessible hydraulic tank and filtration.
- Easy-clean radiator with swing-out AC condenser access.
- Easy access fuse box and electrical components.
- Battery, windscreen wash, grease gun and tool bag storage are all easily accessible.

IN-CAB SERVICE POINTS

- Unrestricted access to air circulation filtration for the AC.
- The easy-lift dual floor panels provide access to hydraulic components, pipework and clustered hydraulic test points.
- In addition, a front of cab low-line service door gives more access to the hydraulic valves.



RELIABLE TRACK DESIGN

Triple flanged rollers support the track in multiple positions improving machine stability. The upper roller maintains track alignment and helps shed debris.

High torque auto step-down travel motors deliver on-demand tracking power when dozing, turning and climbing.



TSS - TAKEUCHI SECURITY SYSTEM

The TB335R comes with **TSS** immobiliser key as standard. Includes 1 red master key and 3 black user keys. Can programme up to 13 user keys.



TB335R SHORT TAIL SWING EXCAVATOR

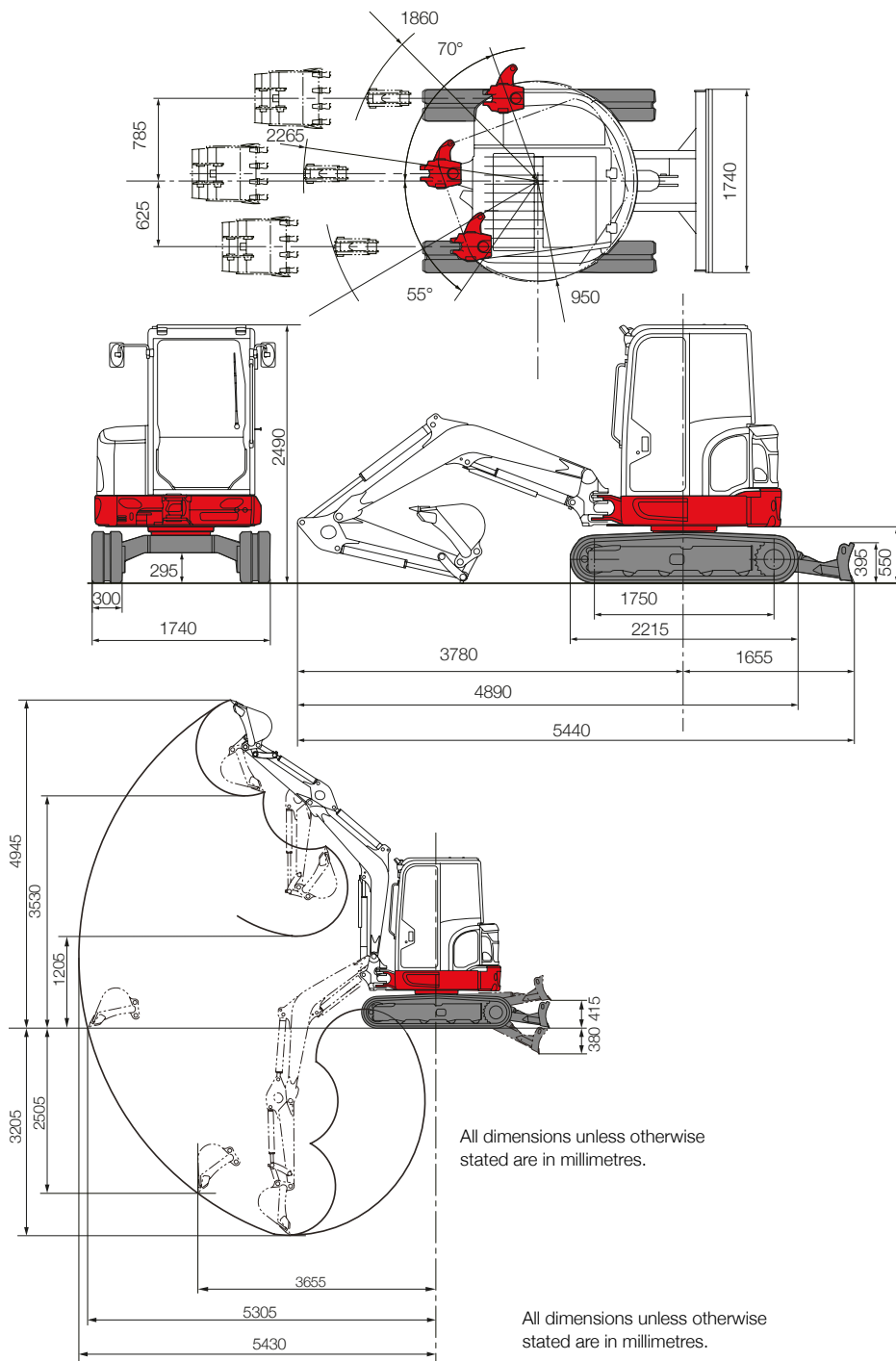

TB335R

Standard UK Specification Cab - Long Arm / Rubber Tracks

Engine	
Make	Kubota
Model	V1505-E4B
Rated Output (kW)/rpm	18.2/2300
Maximum Torque (Nm)	94.3
Cylinders	4
Displacement (cc)	1498
Electrical System	12V 64A

Dimensions & Weight	
Op. Weight (bucket, hitch, fuel) kg	3818
Overall Length (mm) for transport	4890
Width (mm)	1740
Height (mm)	2490
Ground Clearance (mm)	295
Min. Front Swing Radius (mm)	1860
Tail Swing Radius (mm)	950
Dozer Blade (W x H) (mm)	1740 x 395

Operating Information	
Max Digging Depth (mm)	3205
Max Dump Height (mm)	3530
Max Reach at Ground Level (mm)	5305
Max Vertical Digging Depth (mm)	2505
Max Bucket Digging Force (kN)	27.1
Max Arm Digging Force (kN)	19.1

Hydraulic System	
Main System Pressure (bar)	245
Pump Type	Variable x 2 + Gear x 2
1st Auxiliary Maximum Flow (l/min) / Pressure (bar)	64 / 210
2nd Auxiliary Maximum Flow (l/min) / Pressure (bar)	21 / 206

Swing System	
Boom Swing Angle (L/R)	70 / 55
Slew Speed (rpm)	9
Slew Motor	Axial Piston
Slew Brake	Wet Friction Plate

Undercarriage	
Traction Motor	Axial Piston
Traction Drive	Planetary
Traction Brake	Disc
Track Width (mm)	300
Ground Contact Length (mm)	1750
Ground Pressure (kpa)	32.2
Travel Speed (km/h)	3.0/4.1
Maximum Gradeability	25

Capacities	
Hydraulic System (l)	59
Fuel Tank (l)	43.5
Engine Lubrication (l)	6.7
Cooling System (l)	12.5

Health & Safety	
Noise / Sound Power Level (LwA)	93 dB
Vibration Hand Arm / Body m/sec ²	≤2.5 / ≤0.5

12/2024

**FULL
3-YEAR
3,000 HOUR
WARRANTY**

Takeuchi machines come with a full 3 year/3000 hour warranty as standard, terms and conditions apply.

Before fitment of a hydraulic attachment, machine auxiliary pressure and flow should be accurately measured. For all lifting specifications please refer to the lift charts on the Takeuchi website or operator manual.

In accordance with our established policy of constant improvement, we reserve the right to amend these specifications at any time without notice.

Photographs shown may feature non-standard equipment.

For more information locally contact:



SCAN ME

To find your local dealer

Takeuchi Mfg (UK) Ltd, Unit E2B Kingsway Business Park, John Boyd Dunlop Drive, Rochdale, Lancashire OL16 4NG
info@takeuchi-mfg.co.uk www.takeuchi-mfg.co.uk

@TakeuchiUK

TAKEUCHI
From World First to World Leader